

Input: Single-phase 115 – 277 Vac; 600W
Output Load: power supply 24 Vdc; 25 A
Output Battery: charging 24 Vdc; 25 A
Suited for the following battery types: Open Lead Acid, Sealed Lead Acid, lead Gel and Ni-Cd
Automatic diagnostic of battery status.
Charging curve IUoU, constant voltage and constant current
Battery Life Test function (Battery Care)
Switching technology Four charging levels: Recovery, Bulk, Absorption, Boost, and Float
Protected against short circuit and inverted Batt. polarity
Signal output (contact free) for discharged or damaged battery
Signal output (contact free) for Mains or Back-UP
Modbus RTU for all parameter, Battery and System
Ethernet: SNMP V3, Modbus TCP/IP, HTTPS
Protection degree IP20 - DIN rail; Space saving

New revolutionary product, with Ethernet on board provided with protocol connections: HTTPS, SNMPv3, Modbus TCP. The device also features the ADELBus protocol for connecting other ADELSystem devices.

Power Management: Thanks to the All In One units (DC-UPS), it will be possible to optimize power management. The available power is automatically allocated between load and battery, supplying power to the load is the first priority of the unit thus it is not necessary to double the power, because also the power going to the battery will go to the load if the load so requires. The maximum available current on the load output is 3 times the value of the device rated current In.

Battery Care: it's the concept base on algorithms that implement rapid and automatic charging, four state of charge, battery charge optimization during time, flat batteries recovery and real time diagnostic during installation and operation. The Real Time Auto-diagnostic system, monitoring battery faults such as, battery Sulfated, elements in short circuit, accidental reverse polarity connection, disconnection of the battery, they can easily be detected and removed by help of Blink Code of Diagnosis Led or through web server; during the installation and after sell. The continuous monitoring of battery efficiency, reduces battery damage risk and allows a safe operation in permanent connection. Each device is suited for all battery types, by means of manual configuration by push button or web server it is possible setting predefined curves for Open Lead Acid, Sealed Lead Acid, Gel, Ni-Cd(option). They are programmed for five charging levels, recovery, boost, bulk, absorption, float and trickle charge, but they can be changed by the user. A rugged casing for DIN rail mounting, IP20 protection degree. They are extremely compact and cost effective.

Interconnections: The platform communication for ADELSYSTEM devices, allows the connection of all components in a simple but very powerful way, by Ethernet. A protocols communication are based on, MODbus TCP/IP, SNMP or HTTPS. You can select any of the buses depending on your application. It allows to communicate with all the accessories provided by ADELSYSTEM and to develop an independent system for electrical continuity. At the same time, it allows monitoring and control all parameters in the system, even from the other side of the world, by means of application tools on the cloud. ADELSYSTEM allows you to implement very simple but sophisticated monitoring and control for your energy system and opens your mind to new ways to approach your applications.

Norms and Certifications

The CE mark in conformity to EMC 2014/30/EU: Electromagnetic Compatibility Directive; 2014/35/EU: Low Voltage Directive; ROHS 2011/65/EU: Restriction of the use of certain Hazardous Substances in Electrical and Electronic Equipment (RoHS), as amended by 2015/863/EU. EMC Immunity: EN61000-6-2; EMC Emission: EN61000-6-3. According to: Electrical Equipment for Machinery EN 60204; Electrical safety (of information technology equipment) IEC/EN EN62368-1.

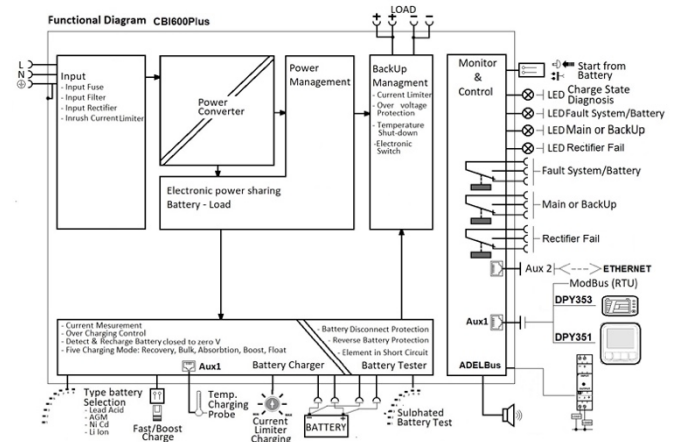

Climatic Data

Ambient temperature (operation)	-25 ÷ +70°C
De Rating Ta > 50°C	- 2.5%(In) / °C
Ambient temperature Storage	-40 ÷ +85°C
Humidity at 25 °C no condensation	95% to 25°C
Altitude: 0 to 2 000m - 0 to 6 560ft	No restrictions
Altitude: 2 000 to 6 000m-6 560 to 20 000ft	De-rating 5°C/1000m
Cooling	Auto convention

General Data

Insulation voltage (IN/OUT)	3000 Vac
Insulation voltage (Input / Earth, PE)	2000 Vac
Insulation voltage (Out Load & Battery / Earth, PE)	500 Vac
Insulation voltage (Out Load, Battery, Aux 2 / Fault System & Main or Back Up terminal)	500 Vac
Protection Class (EN/IEC 60529)	IP20
Reliability: MTBF IEC 61709	> 300.000 h
Pollution Degree Environment	2
Connect Terminal Blocks screw Type Signal	2,5mm(24–14AWG)
Connect Terminal Blocks screw Type Power	4 mm (30-10 AWG)
Protection class (PE Connected)	I, with PE
Dimensions (w-h-d)	150x115x135 mm
Weight	1.55 kg approx.

Input Data

Nominal Input Voltage Vac	115 – 230 – 277
Voltage range Vac	90 – 135 : 180 – 305
Power Factor typ. (115 – 230 Vac)	0.6 – 0.5
Input Inrush Current Limiter	NTC
Inrush Current (Vn – In nom. Load) I2t	≤ 35 A ≤ 5 msec.

All specifications are subject to change without notice
 CBI60024Plus_3.docx

Frequency	47 ÷ 63 Hz
Input Current (115 – 230 Vac)	9 – 4.5 A
Internal fuse (not replaceable)	10 A
External Fuse (recommended) MCB curve B	16 A

Output Data (internal power supply)

Output Voltage (V _n) / Nominal Current (I _n)	24 Vdc
Output Current I _n = I _{load}	25 A
Efficiency (at 50% of rated current)	≥ 91 %
Residual Ripple	≤ 80 mV _{pp}
Turn-On delay after applying mains voltage	1 sec. (max)
Start up with Strong Load (capacitive load)	Yes, Unlimited
Dissipation power load max (W)	48
Short-circuit protection (max current)	Yes (70 A)
Over Load protection (max current)	Yes (60 A)
Over Voltage Output protection	Yes (typ. 35 Vdc)
Overheating Thermal protection	Yes

Battery Charge

Output Voltage Battery	Follow the Out Load
Boost/Fast charge Jumper Config. 25°C (V/cell).	Lead Acid: 2.4 NiCd:1.51; Li-ion: 3.65
Float Charge Jumper Configuration 25°C (V/cell) Jumper Configuration battery type	Lead Acid: 2.23; 2.25; 2.27;2.3 NiCd:1.4; Li-ion: 3.45
Max.Time Boost–Bulk charge (Typ. at IN)	15 h
Min.Time Boost–Bulk charge (Typ. at IN)	1 min.
Recovery Charge	2 – 20 Vdc
Charging current max I _{batt}	25 A ± 5%
Charging current limiting I _{adj}	10 ÷ 100 % / I _{bat}
Reverse battery protection	Yes
Quiescent Current max.	≤ 100 mA
Charging Curve automatic: IUoU	5 stage
Remote Input Control (RTCONN cable)	Boost / Float
Battery charge temperature compensated. External probe	RJTemp 451 or 453 Aux1

Battery Testing

Sulfated battery check (SoH)	Yes
Short circuit Element Detection	Yes
Detection of element in short circuit	Yes
Refresh Battery (must enabled Fast Charge)	Every 288 hours
State of Charge (SoC)	Yes
Low Battery Capacity warning	Yes
Threshold alarm Battery almost flat	21 – 22 Vdc batt
LVD. (Protections against total Batt. discharge)	19 – 20 Vdc batt
Auto or manual test Mode	Yes
Purification Charge	Yes

Load Output

Output voltage Vdc (at I _n)	22 - 28.8 V (31 Ni-Cd)
Nominal current I _{load}	1.1 x I _n A ± 5%
Continuous current (Without battery) I _{load} = I _n	25 A
Continuous current (With battery) I _{load} = I _n + I _{batt}	40 A
Max. current Output Load (Main) I _{load} (4 sec.)	60 A max.
Max. current Output Load (Back Up) I _{load} (4 sec.)	40 A max.
Start From Battery Without Main (Remote Input Control)	RTCONN (cable) Push Button
Time Buffering; min (switch output off without main input)	0.5;2;5;10;15; 20; 30; 45;60;∞

Signal Output (dry switch contacts)

Main or Backup Input Power	Yes
Low Battery	Yes
Fault Battery or system	Yes
Rectifier Alarm	Yes
Acoustic Buzzer selectable, for:	Find the device, Alarm features

Type of Signal Output Contact

Dry Contact. Current can be switched (EN60947.4.1): Max: DC1: 30 Vdc 1 A; AC1: 60 Vac 1A (Resistive load) Min: 1mA at 5 Vdc (Min permissive load)

Fault System / Low Battery	C	NC	NO
Main or Back Up	C	NC	NO
Rectifier Fail	C	NC	NO

Communication Port: Input / Output (RJ45)

Remote monitoring data Protocol:	Aux 1 Modbus RTU (RS485)
Ethernet communication protocols:	ModBus TCP/IP - SNMP V3 - HTTPS
ADEBus	CAN Open

GUI

GUI: Embedded web based accessed via Ethernet using:	Web Server
--	------------

Device feature

User configurable Alarm	By Web Server
User configurable signals	By Web Server
Downloadable software and firmware upgrades	

PC Shutdown or Device Shutdown

PC Shutdown function to switch Off and On PC	By ADELViewSystem and RJUSB280 Cable
Switch off device if Ethernet looses the communication	By setting the device.

LED Indicator

Charging Mode	Green
Diagnosis	Red
Battery / System fault	Red
Mains or Back Up	Yellow
Rectifier fail	Red

LOG File

Life time Battery statistic History:	N° of complete Charging, N° of aborted Charging, Tot. Ampere hours, Tot. Run Time, Highest Voltage, Lowest Voltage, N° Power Boost, Max. deep of discharge, Average deep of discharge,
Life time Device statistic History:	N° of internal overtemperature event
Life time Input statistic History:	N° of Time the Vac is lower than min. edge, N° of Time the Vac is higher than max. edge, N° of Back Up, Max. AC Voltage, Min AC Voltage.
Life time Load statistic History:	Highest Voltage on the Load Terminal, Lowest Voltage on the Load Terminal
Alarm Battery Log:	Battery element shorted, Battery temperature, Bad cable connections, Low state of Health SoH, Revers battery connection, Temperature sensor disconnected.
Alarm Input Log:	Input Vac Lower then or Higher then...,

Alarm Load Log:	Output in Short circuit, Output in overload.
Notification	Email Alarm

Lifetime Expectancy

Life Time Expectancy defines the minimum life expectancy of the device in hours of operation. Being a device designed with electrolytic capacitors, the maximum duration is defined at 15 years - 131,400 h. Any value higher than this is to be considered only as a theoretical duration, calculated to be able to compare devices with each other.

Ambient temp.	Out Power	115Vac	230Vac
25°C	24 Vdc - 10 A	642640h	883243h
25°C	24 Vdc - 20 A	158844h	634203h
40°C	24 Vdc - 10 A	187139h	292603h
40°C	24 Vdc - 20 A	25846h	182768h

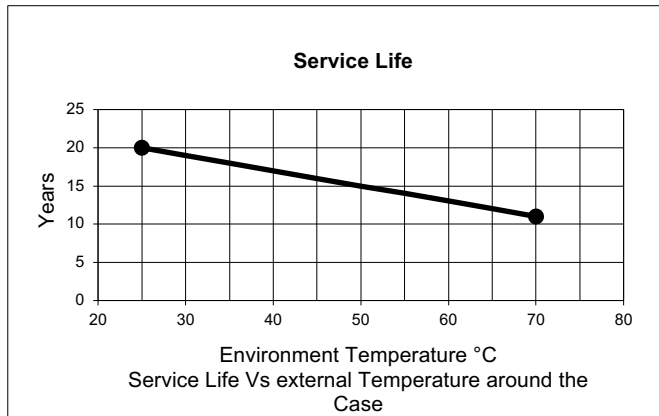

Accuracy Measurement

Accuracy on the Input side

Measure of the Main Input voltage at 47- 63Hz; $\pm 25^\circ\text{C}$; 90 – 305 Vac	$\pm 1\%$ of Full Scale Vac
--	--------------------------------

Accuracy on the output side

Measure of the Output voltage Load Side Range: 10 - 33Vdc	$\pm 1.5\%$ of Full Scale Vdc Out
Measure of the Output current Load Side Range: 0 - 70A	$\pm 1.5\%$ of Full Scale I Out
Measure of the Output voltage Battery Side Range: 0 - 33V	$\pm 1.5\%$ of Full Scale Vdc Out
Measure of the Output current Battery Side Range: 0 - 30A	$\pm 1.5\%$ of Full Scale I Out
Temperature Probe Range: -20 – 60°C	$\pm 2^\circ\text{C}$

Accessory

RTCONN	Cable Start from battery Length 1m. Jumper 6
RJTEMP451	Temperature Probe Length 1m.
RJTEMP453	Temperature Probe Length 3m.
RJCONN45	Cable RJ45/RJ45 for Parallel Connection or connection to DPY351
RJ45COUPLER	RJ45 Three way "Daisy Chain" for Aux 2
RJUSB280	Cable RJ45/USB (Aux2) Length 1m for connection to PC.
RJTB280	Connector RJ45/Terminal Block 4pin for Aux 2 To RS485 ModBus RTU
ADELViewsystem	PC App for: Monitoring, Logging, Configuration, Control, Alarm, of the devices in ADELBus network.
DPY351	HMI panel control for: Monitoring, Logging, Configuration, Control, Alarm, of the devices in ADELBus network.
DPY353	Display for: Monitoring the Battery state, Battery Charging Section.

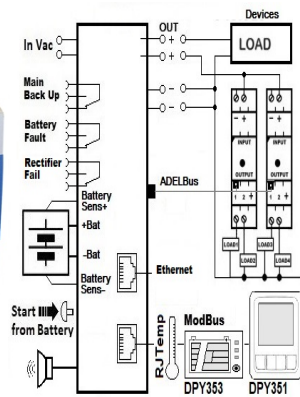

- Input:** Single-phase 115 – 277 Vac; 600W
- Output Load:** power supply 48 Vdc; 12.5 A
- Output Battery:** charging 48 Vdc; 12.5 A
- Suited for the following battery types:** Open Lead Acid, Sealed Lead Acid, lead Gel and Ni-Cd
- Automatic diagnostic of battery status.**
- Charging curve IUoU, constant voltage and constant current**
- Battery Life Test function (Battery Care)**
- Switching technology** Four charging levels: Recovery, Bulk, Absorption, Boost, and Float
- Protected against short circuit and inverted Batt. polarity**
- Signal output (contact free) for discharged or damaged battery**
- Signal output (contact free) for Mains or Back-UP**
- Modbus RTU for all parameter, Battery and System**
- Ethernet: SNMP V3, Modbus TCP/IP, HTTPS**
- Protection degree IP20 - DIN rail; Space saving**

New revolutionary product, with Ethernet on board provided with protocol connections: HTTPS, SNMPv3, Modbus TCP. The device also features the ADELBus protocol for connecting other ADELSystem devices.

Power Management: Thanks to the All In One units (DC-UPS), it will be possible to optimize power management. The available power is automatically allocated between load and battery, supplying power to the load is the first priority of the unit thus it is not necessary to double the power, because also the power going to the battery will go to the load if the load so requires. The maximum available current on the load output is 3 times the value of the device rated current In.

Battery Care: it's the concept base on algorithms that implement rapid and automatic charging, four state of charge, battery charge optimization during time, flat batteries recovery and real time diagnostic during installation and operation. The Real Time Auto-diagnostic system, monitoring battery faults such as, battery Sulfated, elements in short circuit, accidental reverse polarity connection, disconnection of the battery, they can easily be detected and removed by help of Blink Code of Diagnosis Led or through web server; during the installation and after sell. The continuous monitoring of battery efficiency, reduces battery damage risk and allows a safe operation in permanent connection. Each device is suited for all battery types, by means of manual configuration by push button or web server it is possible setting predefined curves for Open Lead Acid, Sealed Lead Acid, Gel, Ni-Cd(option). They are programmed for five charging levels, recovery, boost, bulk, absorption, float and trickle charge, but they can be changed by the user. A rugged casing for DIN rail mounting, IP20 protection degree. They are extremely compact and cost effective.

Interconnections: The platform communication for ADELSYSTEM devices, allows the connection of all components in a simple but very powerful way, by Ethernet. A protocols communication are based on, MODbus TCP/IP, SNMP or HTTPS. You can select any of the buses depending on your application. It allows to communicate with all the accessories provided by ADELSYSTEM and to develop an independent system for electrical continuity. At the same time, it allows monitoring and control all parameters in the system, even from the other side of the world, by means of application tools on the cloud. ADELSYSTEM allows you to implement very simple but sophisticated monitoring and control for your energy system and opens your mind to new ways to approach your applications.

Norms and Certifications

The CE mark in conformity to EMC 2014/30/EU: Electromagnetic Compatibility Directive; 2014/35/EU: Low Voltage Directive; ROHS 2011/65/EU: Restriction of the use of certain Hazardous Substances in Electrical and Electronic Equipment (RoHS), as amended by 2015/863/EU. EMC Immunity: EN61000-6-2; EMC Emission: EN61000-6-3. According to: Electrical Equipment for Machinery EN 60204; Electrical safety (of information technology equipment) IEC/EN EN62368-1.

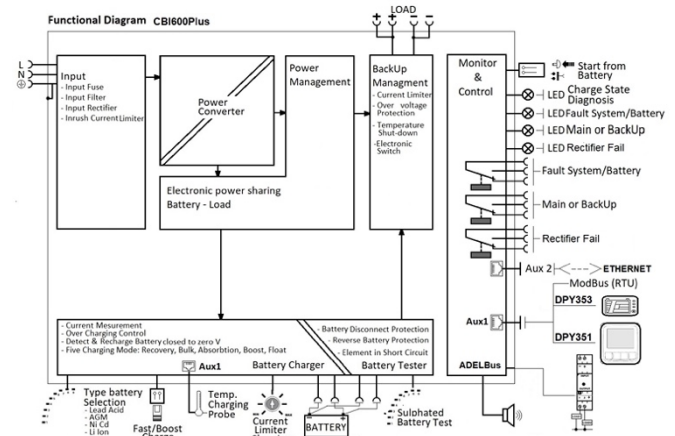

Climatic Data

Ambient temperature (operation)	-25 ÷ +70°C
De Rating Ta > 50°C	- 2.5%(In) / °C
Ambient temperature Storage	-40 ÷ +85°C
Humidity at 25 °C no condensation	95% to 25°C
Altitude: 0 to 2 000m - 0 to 6 560ft	No restrictions
Altitude: 2 000 to 6 000m-6 560 to 20 000ft	De-rating 5°C/1000m
Cooling	Auto convention

General Data

Insulation voltage (IN/OUT)	3000 Vac
Insulation voltage (Input / Earth, PE)	2000 Vac
Insulation voltage (Out Load & Battery / Earth, PE)	500 Vac
Insulation voltage (Out Load, Battery, Aux2 / Fault System & Main or Back Up terminal)	500 Vac
Protection Class (EN/IEC 60529)	IP20
Reliability: MTBF IEC 61709	> 300.000 h
Pollution Degree Environment	2
Connect Terminal Blocks screw Type Signal	2,5mm(24–14AWG)
Connect Terminal Blocks screw Type Power	4 mm (30-10 AWG)
Protection class (PE Connected)	I, with PE
Dimensions (w-h-d)	150x115x135 mm
Weight	1.55 kg approx.

Input Data

Nominal Input Voltage Vac	115 – 230 – 277
Voltage range Vac	90 – 135 : 180 – 305
Power Factor typ. (115 – 230 Vac)	0.6 – 0.5
Input Inrush Current Limiter	NTC

All specifications are subject to change without notice
CBI60048Plus_3.docx

Inrush Current (Vn – In nom. Load) I2t	≤ 35 A ≤ 5 msec.
Frequency	47 ÷ 63 Hz
Input Current (115 – 230 Vac)	9 – 4.5 A
Internal fuse (not replaceable)	10 A
External Fuse (recommended) MCB curve B	16 A

Output Data (internal power supply)

Output Voltage (Vn) / Nominal Current (In)	48 Vdc
Output Current In = Iload	12.5 A
Efficiency (at 50% of rated current)	≥ 91 %
Ripple and Noise (20 MHz Bandwidth)	≤ 80 mV _{pp} (max)
Turn-On delay after applying mains voltage	1 sec. (max)
Start up with Strong Load (capacitive load)	Yes, Unlimited
Dissipation power load max (W)	54
Short-circuit protection (max current)	Yes (38 A)
Over Load protection (max current)	Yes (35 A)
Over Voltage Output protection	Yes (typ. 72 Vdc)
Overheating Thermal protection	Yes

Battery Charge

Output Voltage Battery	Follow the Out Load
Boost/Fast charge Jumper Config. 25°C (V/cell).	Lead Acid: 2.4 NiCd:1.51; Li-ion: 3.65
Float Charge Jumper Configuration 25°C (V/cell) Jumper Configuration battery type	Lead Acid: 2.23; 2.25; 2.27;2.3 NiCd:1.4; Li-ion: 3.45
Max.Time Boost–Bulk charge (Typ. at IN)	15 h
Min.Time Boost–Bulk charge (Typ. at IN)	1 min.
Recovery Charge	6 – 42 Vdc
Charging current max I _{batt}	12.5 A ± 5%
Charging current limiting I _{adj}	10 ÷ 100 % / I _{bat}
Reverse battery protection	Yes
Quiescent Current max.	≤ 100 mA
Charging Curve automatic: IUoU	5 stage
Remote Input Control (RTCONN cable)	Boost / Float
Battery charge temperature compensated. External probe	RJTemp 451 or 453 Aux1

Battery Testing

Sulfated battery check (SoH)	Yes
Short circuit Element Detection	Yes
Detection of element in short circuit	Yes
Refresh Battery (must enabled Fast Charge)	Every 288 hours
State of Charge (SoC)	Yes
Low Battery Capacity warning	Yes
Threshold alarm Battery almost flat	44 – 46 Vdc batt
LVD. (Protections against total Batt. discharge)	40 – 42 Vdc batt
Auto or manual test Mode	Yes
Purification Charge	Yes

Load Output

Output voltage Vdc (at In)	44 - 57.6 V (60.4 Ni-Cd)
Nominal current I _{load}	1.1 x In A ± 5%
Continuous current (Without battery) I _{load} = In	12.5 A
Continuous current (With battery)	25 A
I _{load} = In+ I _{batt}	
Max. current Output Load (Main) I _{load} (4 sec.)	38 A max.
Max. current Output Load (Back Up)	25 A max.
I _{load} (4 sec.)	
Start From Battery Without Main (Remote Input Control)	RTCONN (cable) Push Button

Time Buffering; min (switch output off without main input)	0.5;2;5;10;15; 20; 30; 45;60;∞
--	-----------------------------------

Signal Output (dry switch contacts)

Main or Backup Input Power	Ye(max)s
Low Battery	Yes
Fault Battery or system	Yes
Rectifier Alarm	Yes
Acoustic Buzzer selectable, for:	Find the device, Alarm features

Type of Signal Output Contact

Dry Contact. Current can be switched (EN60947.4.1): Max: DC1: 30 Vdc 1 A; AC1: 60 Vac 1A (Resistive load) Min: 1mA at 5 Vdc (Min permissive load)

Fault System / Low Battery	C	NC	NO
Main or Back Up	C	NC	NO
Rectifier Fail	C	NC	NO

Communication Port: Input / Output (RJ45)

Remote monitoring data Protocol:	Aux 1 Modbus RTU (RS485)
Ethernet communication protocols:	ModBus TCP/IP - SNMP V3 - HTTPS
ADELBus	CAN Open

GUI

GUI: Embedded web based accessed via Ethernet using:	Web Server
--	------------

Device feature

User configurable Alarm	By Web Server
User configurable signals	By Web Server
Downloadable software and firmware upgrades	

PC Shutdown or Device Shutdown

PC Shutdown function to switch Off and On PC	By ADELViewSystem and RJUSB280 Cable
Switch off device if Ethernet loos the communication	By setting the device.

LED Indicator

Charging Mode	Green
Diagnosis	Red
Battery / System fault	Red
Mains or Back Up	Yellow
Rectifier fail	Red

LOG File

Life time Battery statistic History:	N° of complete Charging, N° of aborted Charging, Tot. Ampere hours, Tot. Run Time, Highest Voltage, Lowest Voltage, N° Power Boost, Max. deep of discharge, Average deep of discharge,
Life time Device statistic History:	N° of internal overtemperature event
Life time Input statistic History:	N° of Time the Vac is lower than min. edge, N° of Time the Vac is higher than max. edge, N° of Back Up, Max. AC Voltage, Min AC Voltage.
Life time Load statistic History:	Highest Voltage on the Load Terminal, Lowest Voltage on the Load Terminal
Alarm Battery Log:	Battery element shorted, Battery temperature, Bad cable connections, Low state of Health SoH, Revers battery connection, Temperature sensor disconnected.

Alarm Input Log:	Input Vac Lower then or Higher then...,
Alarm Load Log:	Output in Short circuit, Output in overload.
Notification	Email Alarm

DPY351	HMI panel control for: Monitoring, Logging, Configuration, Control, Alarm, of the devices in ADElBus network.
DPY353	Display for: Monitoring the Battery state, Battery Charging Section.

Lifetime Expectancy

Life Time Expectancy defines the minimum life expectancy of the device in hours of operation. Being a device designed with electrolytic capacitors, the maximum duration is defined at 15 years - 131,400 h. Any value higher than this is to be considered only as a theoretical duration, calculated to be able to compare devices with each other.

Ambient temp.	Out Power	115Vac	230Vac
25°C	48 Vdc - 5 A	642640h	883243h
25°C	48 Vdc - 10 A	158844h	634203h
40°C	48 Vdc - 5 A	187139h	292603h
40°C	48 Vdc - 10 A	25846h	182768h

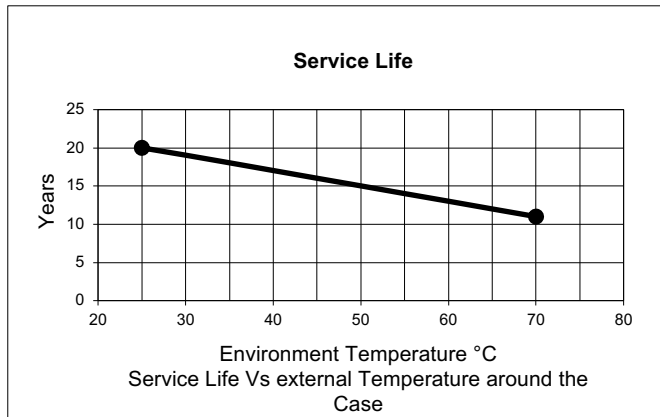

Accuracy Measurement

Accuracy on the Input side

Measure of the Main Input voltage at 47- 63Hz; $\pm 25^{\circ}\text{C}$; 90 – 305 Vac	$\pm 1 \%$ of Full Scale Vac
--	--

Accuracy on the output side

Measure of the Output voltage Load Side Range: 10 – 66 Vdc	$\pm 1.5\%$ of Full Scale Vdc Out
Measure of the Output current Load Side Range: 0 -40 A	$\pm 1.5\%$ of Full Scale I Out
Measure of the Output voltage Battery Side Range: 0 – 66 V	$\pm 1.5\%$ of Full Scale Vdc Out
Measure of the Output current Battery Side Range: 0 – 20 A	$\pm 1.5\%$ of Full Scale I Out
Temperature Probe Range:-20 – 60°C	$\pm 2^{\circ}\text{C}$

Accessory

RTCONN	Cable Start from battery Length 1m. Jumper 6
RJTEMP451	Temperature Probe Length 1m.
RJTEMP453	Temperature Probe Length 3m.
RJCONN45	Cable RJ45/RJ45 for Parallel Connection or connection to DPY351
RJ45COUPLER	RJ45 Three way "Daisy Chain" for Aux 2
RJUSB280	Cable RJ45/USB (Aux2) Length 1m for connection to PC.
RJTB280	Connector RJ45/Terminal Block 4pin for Aux 2 To RS485 ModBus RTU
ADELViewsystem (Aux1 RTU485)	PC App for: Monitoring, Logging, Configuration, Control, Alarm, of the devices in ADElBus network.